

# SUBMITTAL INFORMATION

## Stainless Steel Tapping Sleeve - (FASTP-xxxx-x style)

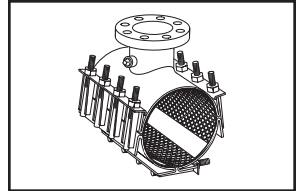

### STAINLESS STEEL TAPPING SLEEVE FOR HDPE PIPE

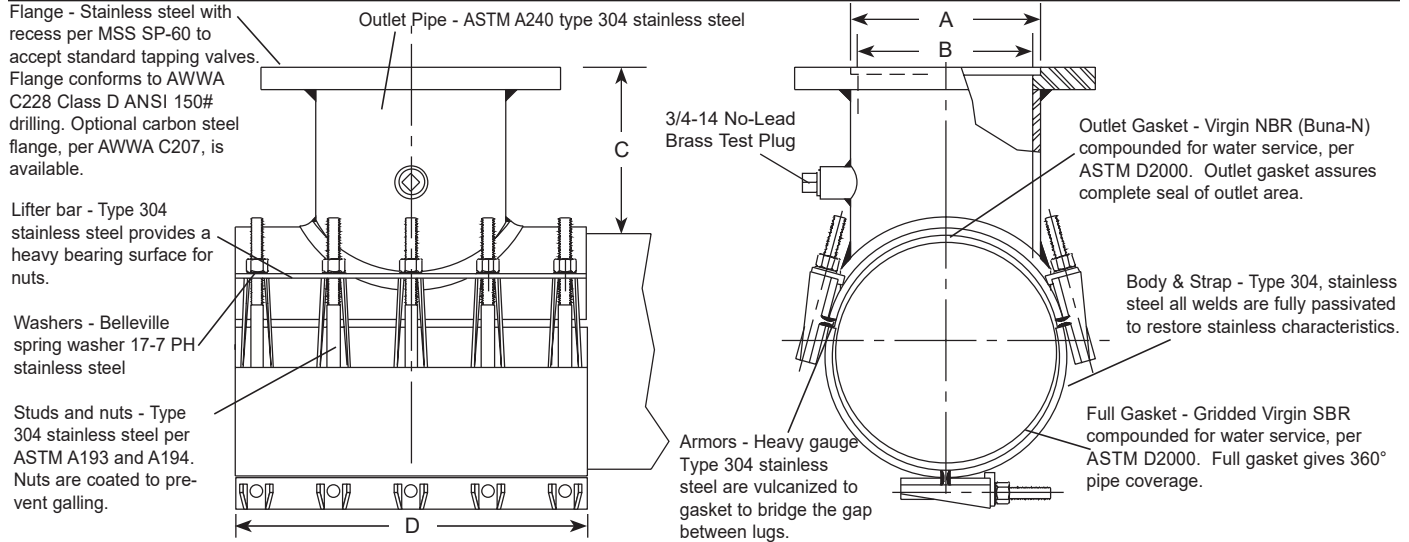

NOM. PIPE SIZE (IN.)	SLEEVE O.D. RANGE (IN.)	NOMINAL DIMENSIONS - INCHES					MIN. NUMBER OF BOLTS	SIZE OF BOLTS	APPROX. WT. LBS.	CATALOG NUMBER**	
		FLANGE SIZE (IN.)	COUNTER-BORE ID	OUTLET PIPE ID		TOP OF PIPE TO TOP OF FLANGE					WIDTH
				A	B						
16	16.00 17.40	2	3-1/16	3-1/4	5-3/8	16	15	5/8"	73	FASTP-1600-x FASTP-1740-x	
		3	4-1/16	3-1/4	4-15/16	16	15	5/8"	74		
		4	5-1/16	4-1/4	4-15/16	16	15	5/8"	75		
		6	7-1/16	6-13/32	5-1/4	16	15	5/8"	78		
		8	9-1/16	8-13/32	5-3/8	20	14	5/8"	100		
		10	11-1/16	10-15/32	5-7/8	20	14	5/8"	114		
18	18.00 19.50	12	13-1/16	12-13/32	6	24	16	5/8"	146	FASTP-1800-x FASTP-1950-x	
		2	3-1/16	3-1/4	5-3/8	16	15	5/8"	79		
		3	4-1/16	3-1/4	4-15/16	16	15	5/8"	80		
		4	5-1/16	4-1/4	4-15/16	16	15	5/8"	81		
		6	7-1/16	6-13/32	5-1/4	16	15	5/8"	86		
		8	9-1/16	8-13/32	5-3/8	20	14	5/8"	106		
20	20.00 21.60	10	11-1/16	10-15/32	5-7/8	20	14	5/8"	119	FASTP-2000-x FASTP-2160-x	
		12	13-1/16	12-13/32	6	24	16	5/8"	153		
		2	3-1/16	3-1/4	5-3/8	16	15	5/8"	85		
		3	4-1/16	3-1/4	4-15/16	16	15	5/8"	86		
		4	5-1/16	4-1/4	4-15/16	16	15	5/8"	87		
		6	7-1/16	6-13/32	5-1/4	16	15	5/8"	92		
24	24.00 25.80 26.00	8	9-1/16	8-13/32	5-3/8	20	14	5/8"	114	FASTP-2400-x FASTP-2580-x FASTP-2600-x	
		10	11-1/16	10-15/32	5-7/8	20	14	5/8"	124		
		12	13-1/16	12-13/32	6	24	16	5/8"	159		
		2	3-1/16	3-1/4	5-3/8	16	15	5/8"	97		
		3	4-1/16	3-1/4	4-15/16	16	15	5/8"	98		
		4	5-1/16	4-1/4	4-15/16	16	15	5/8"	99		

\*\* To order: Add flanged outlet size to catalog number. Example: The complete FASTP catalog number for a 20" pipe (21.60 O.D.) with a 12" stainless steel flange is FASTP-2160-12. For a carbon steel flange, add "A" to the catalog number. Example: FASTP-2160-12A

### FEATURES

- Body, straps and UNC threaded studs are made of type 304 stainless steel
- Flange can be either type 304 stainless steel or ASTM A36 carbon steel
- All sleeves are fully passivated for corrosion resistance
- Outlet gasket is NBR (Buna-N) rubber per ASTM D2000
- Belleville spring washers allow for limited pipe expansion and contraction
- 16" rated to 200 psi, 18"-20" rated to 175 psi, 24" rated to 150 psi. Rating not to exceed the pressure rating of the pipe.
- Certified to ANSI/NSF Standard 61

The Ford Meter Box Company considers the information in this submittal form to be correct at the time of publication. Item and option availability, including specifications, are subject to change without notice. Please verify that your product information is current. Our standard warranty applies.



**The Ford Meter Box Company, Inc.**  
 P.O. Box 443, Wabash, Indiana U.S.A. 46992-0443  
 Phone: 260-563-3171 / Fax: 800-826-3487  
 Overseas Fax: 260-563-0167  
 www.fordmeterbox.com

09/13/22

Submitted By: