

SUBMITTAL INFORMATION

Fabricated Bell Joint Leak Clamp - (FBCF-xxx style)

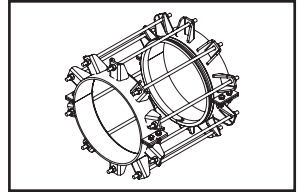

FABRICATED BELL JOINT REPAIR CLAMPS FOR DUCTILE AND C900 PIPE

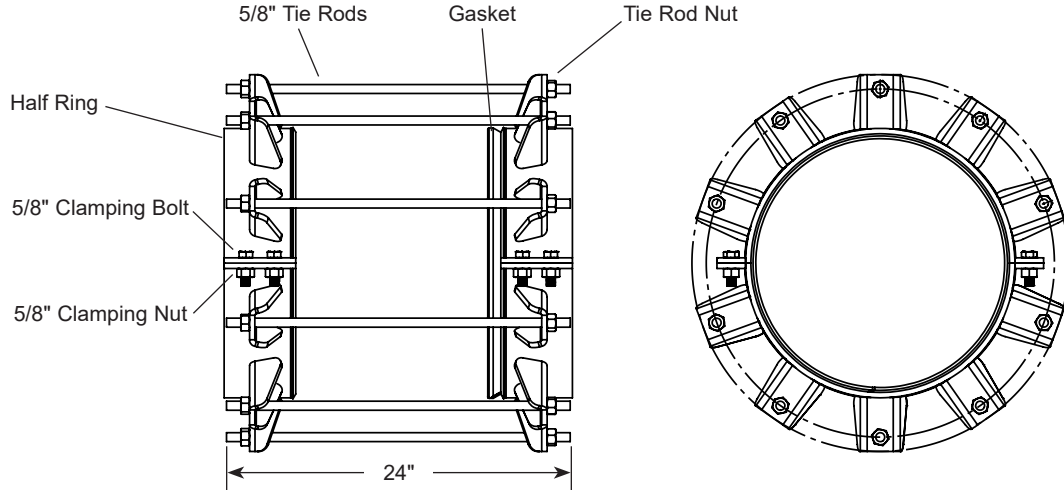

NOM. PIPE SIZE	CATALOG NUMBER	SIZE (IN.)	*MAX BELL CLEARANCE	APPROX. WT. LBS.	✓ SUBMITTED ITEM(S)
14"	FBCF-1530	15.30	23-1/2"	120.1	
16"	FBCF-1740	17.40	25-9/16"	140.9	
18"	FBCF-1950	19.50	27-11/16"	160.6	
20"	FBCF-2160	21.60	29-13/16"	167.5	
24"	FBCF-2580	25.80	34"	207.8	
30"	FBCF-3200	32.00	40-3/16"	231.2	
36"	FBCF-3830	38.30	46-1/2"	263.3	
42"	FBCF-4450	44.50	52-11/16"	345.0	

* Contact factory for larger pipe bells.

Note: For use on C900 PVC, add "-C900" to end of the catalog number.

Example: FBCF-1530-C900. This option will include longer bolts to accommodate a C900 PVC pipe bell.

FEATURES

- Half Rings - Carbon steel per ASTM A36, with enamel paint
- Tie Rods - High strength, low alloy steel per ASTM A242 and AWWA C111
- Bolts and nuts - High strength, low alloy steel per ASTM A242 and AWWA C111
- Gaskets - SBR rubber per ASTM D2000

The Ford Meter Box Company considers the information in this submittal form to be correct at the time of publication. Item and option availability, including specifications, are subject to change without notice. Please verify that your product information is current. Our standard warranty applies.



The Ford Meter Box Company, Inc.

P.O. Box 443, Wabash, Indiana U.S.A. 46992-0443

Phone: 260-563-3171 / Fax: 800-826-3487

Overseas Fax: 260-563-0167

www.fordmeterbox.com

02/29/24

Submitted By: