

SUBMITTAL INFORMATION

Pitometer Handle - (HP-4 style)

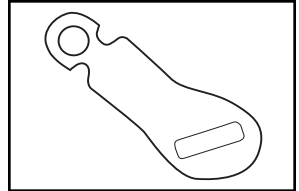

SPECIAL ANGLE LEVER HANDLE FOR 3/4" AND 1" BALL VALVES FOR PITOMETER SERVICE

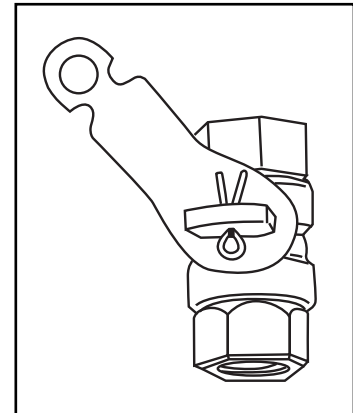
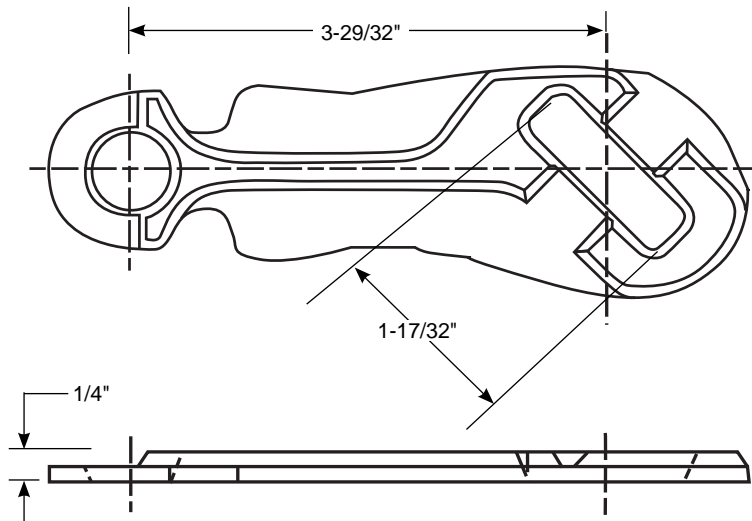

BALL VALVE SIZE	LENGTH	WIDTH	APPROX. WT. LBS	PART NUMBER	✓ SUBMITTED ITEM(S)
3/4" or 1"	3-29/32"	13/16"	0.4	HP-4	

FEATURES

- All brass conforms to AWWA Standard C800 (ASTM B-62 and ASTM B-584, UNS NO C83600 - 85-5-5-5)
- Handle provides easy cycling of a straight ball valve
- Cotter pin furnished to attach handle to tee-head

The Ford Meter Box Company considers the information in this submittal form to be correct at the time of publication. Item and option availability, including specifications, are subject to change without notice. Please verify that your product information is current.



The Ford Meter Box Company, Inc.

P.O. Box 443, Wabash, Indiana U.S.A. 46992-0443

Phone: 260-563-3171 / Fax: 800-826-3487

Overseas Fax: 260-563-0167

<http://www.fordmeterbox.com>

06/23/09

Submitted By: